

K&F NOMOS XLS



User's Manual

Translation of the original instructions

Version 1.6

Released: 21.11.2017



**Important Information,
Please Read Before Use!**

KLING & FREITAG GmbH
Junkersstraße 14
D-30179 Hannover
TEL +49 (0) 511 96 99 70
FAX +49 (0) 511 67 37 94
www.kling-freitag.de

KLING &
FREITAG

SOUND SYSTEMS

Table of contents

1	Introduction	5
1.1	Icons Used	5
1.2	About this Manual	5
2	Product Description	6
2.1	Items Included	6
2.2	Components	6
2.3	System Requirements	7
3	Safety Instructions	7
3.1	Notes for Mounting the Speakers	7
3.2	Instructions for Speaker Stacking	8
3.3	Protecting the Speakers / Operating Safety	8
4	Installation	10
4.1	Removing the Transport Covers	10
4.2	Stacked Setup	10
5	Suspending the Speakers	11
5.1	Safety instructions for flight configurations	11
5.1.1	Safety Instructions for Flying Configurations	11
5.1.2	Wind Loading	11
5.2	NOMOS XLS Option 'Flight'	13
5.3	Possible options for flying point positions	14
6	Configuration and Connecting Diagram	16
6.1	Terminal assignment	16
6.2	NOMOS XLS combined with other K&F tops.	17
6.3	Cardioid Arrays with NOMOS XLS	18
6.3.1	Setup instructions for a cardioid array	18
6.3.2	LSBlocks for cardioid use	19
6.4	Cardioid Configurations with different Speakers	20
7	Fuse in the NOMOS XLS	20
7.1	Replacing the Fuses	20
7.2	Replacing the Chassis	20
8	Dimensions NOMOS XLS	21
9	Measuring Diagrams	22
10	Technical Specifications	23
11	EC Declaration of Conformity	24
12	Accessories	25
13	Care and Maintenance	26

14	Transportation and Storage	26
15	Disposal	27
15.1	Germany	27
15.2	EU, Norway, Iceland, and Liechtenstein	27
15.3	All Other Countries	27

1. Introduction

Thank you for purchasing a KLING & FREITAG product. To guarantee a trouble-free operating of the equipment and to allow your KLING & FREITAG NOMOS XLS system to achieve its full potential read the user's manual carefully before use. As the owner of a NOMOS XLS loudspeaker, you now have a versatile and highly professional tool which, when operated properly, is a true pleasure to use.

1.1 Icons Used



Warning

This icon indicates a risk of injury or death. Not following these instructions may result in serious health problems including potentially fatal injuries.



Caution

This icon indicates a possibly dangerous situation. Not following these instructions may cause minor injuries or damage.



Notice

This icon marks instructions for proper use of the described products. Not following these instructions may cause malfunctions or damage.



Tip

This icon marks information provided for simplified use of the described products.

1.2 About this Manual

© KLING & FREITAG GmbH. All rights reserved.

All specifications regarding the features of the described products and applicable safety guidelines provided in this manual are based on information available at the time of publishing.

We assume no responsibility for technical specifications, dimensions, weights, and properties.

All information in this manual is subject to change without notice.

All persons who use the speaker system must have this guide and all further information for safe operations available to them during assembly, disassembly, and use. The speaker system may neither be set up nor used until these user's manual has been read, understood and kept readily available in site.

All KLING & FREITAG manuals are originally authored in German.

KLING & FREITAG spare manuals are separately available for order or can be downloaded from our website: www.kling-freitag.de.

Contact Us: info@kling-freitag.de
KLING & FREITAG GMBH, Junkersstr. 14, D-30179 Hannover
Phone +49 511 96 99 70, fax +49 511 67 37 94 (other countries)

2. Product Description

2.1 Items Included

- Subwoofer NOMOS XLS
- User's Manual

2.2 Components

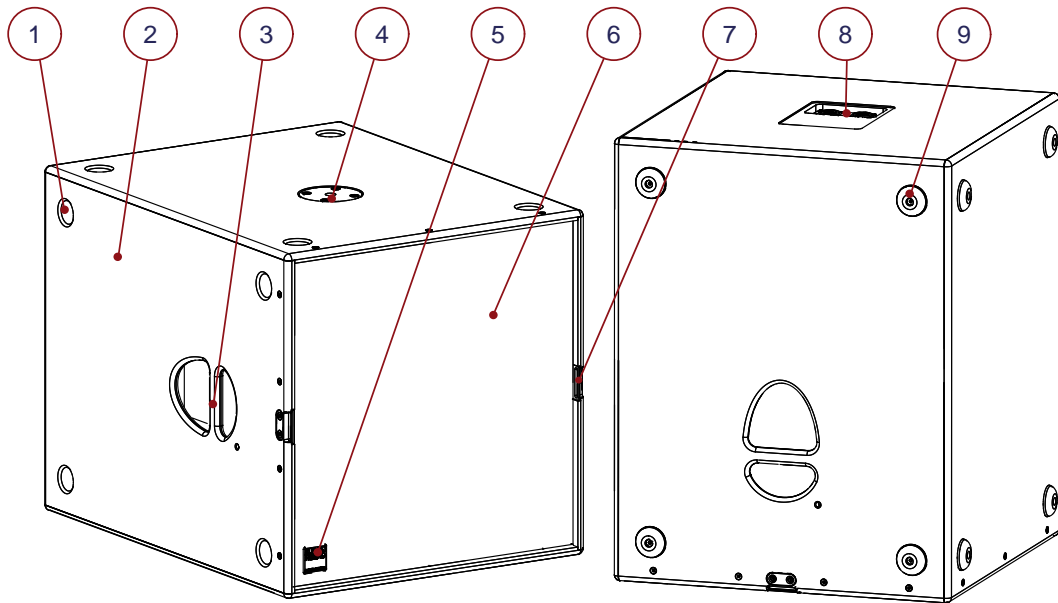

1. Stacking grooves (8x) , adjacent: plastic glider
2. speaker enclosure
3. handle (2x)
4. Threaded stand flange
5. Speakon connector, front (behind company logo)
6. Front grille with acoustic foam
7. locking profiles for transport cover (2x)
8. Plastic glider (8x) , adjacent: stacking grooves
9. SpeakOn connector

2.3 System Requirements

K&F PLM+ 20k44 (SystemAmp, ProRental)
K&F PLM+ 12k44 (SystemAmp, ProRental)

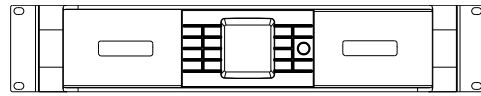

or

K&F D200:4 (SystemAmp, InstallSound)
K&F D120:4 (SystemAmp, InstallSound)
K&F D80:4 (SystemAmp, InstallSound)

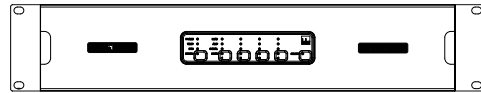

or

K&F SystemRack:

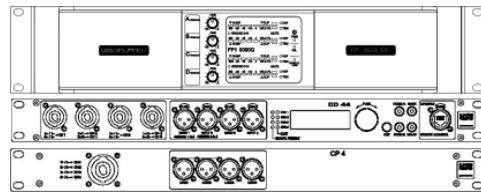

3. Safety Instructions



Warning

For commercial use as specified in this document only!

To prevent personal injury and damage, be sure to securely place or suspend the speaker as specified in the locally applicable standards.

The information described here does not relieve the user of the duty to follow the given safety requirements and legal regulations.

Only qualified technicians are permitted to perform the installation steps. Be sure to use personal protective equipment at all times.

The persons in charge with putting up the speaker are responsible for safe setup and use and must guarantee it.

In mobile and stationary installations, always use installation parts supplied by KLING & FREITAG.

Unless otherwise stated, use KLING & FREITAG original parts only. Never use other parts (in particular, parts not made by KLING & FREITAG).

Be sure to always visually inspect all safety-related speaker and accessory components before use. In fixed installations, check the speaker for signs of wear at regular intervals. If there are signs of wear, cracks, or deformation, etc., replace the affected parts immediately.



Caution

Run the cables in a way that nobody can trip over them.

At least 2 people are necessary to carry the speaker.

Preventing Hearing Damage

Keep your distance from operating speakers. Even loudness levels of approx. 90 dB - that you subjectively judge as being low - can lead to hearing damage.

3.1 Notes for Mounting the Speakers



Warning

Mount the speakers securely. To avoid injury or damage, always be sure to mount the speakers securely so that they do not fall.

Note that speakers can move as a result of vibrations. To prevent them from falling from their mounted position, they must be secured properly.

Run the cables in a way that nobody can trip over them.

3.2 Instructions for Speaker Stacking



Warning

Falling speakers pose the threat of fatal injuries to people near them!

Be sure to follow the relevant national specifications, norms, and safety regulations.

Always make sure that a sufficient safety level is still given, even when outside forces have an additional impact on the stacked speakers. Before setup, carefully ascertain if there are any possible outside forces that could result in the system falling over. (Slant of the ground / the bearing capacity of the ground / wind / person or vehicle impact, etc.). A technical expert who is responsible for the setup must evaluate and determine necessary measures (including calculating the statics). If necessary, obtain expert proof of stability.

Stacked systems may not fall over even if they are inclined by 15° in each direction. If this requirement is not fulfilled, then it is necessary to take steps to achieve compliance. Possible measures include strapping it to an appropriate base structure or fastening it using safety straps. A planned tilt of the loudspeakers is not permissible. In calculations, the tilted setup serves the purpose of levelling out unevenness.

With the set-up systems for which you cannot verify the structural safety without safeguards, you must secure them to prevent sliding or tipping in order to provide proof of this safety. To secure the system from tipping over, use water tanks or floor bolts. Other possible measures include strapping it to a suitable substructure or tying it using safety straps.

For outdoor and trade fair venues in which wind loads must be considered, additional proof of stability is necessary.

Make sure that the stacking feet of subwoofers stacked on top of one another are securely positioned in the grooves of the lower speaker.

If you place a top speaker on a NOMOS XLS you must always strap the speakers to one another and secure them from falling over.

3.3 Protecting the Speakers / Operating Safety



Notice

NOMOS XLS speakers may only be used in combination with a K&F SystemAmp/SystemRack.

In general, audio signals must not be overdriven. This may be caused by mixing consoles, equalizers, effect equipment, etc. and should be indicated on this equipment. When a power amplifier is overloaded at the output (clipping), then the amplifier activates a clipping warning signal. In any case, the signal must be reduced as soon as it sounds unnaturally distorted.

For damage caused by

- overloading the speakers or
- using the speakers without K&F SystemAmp/SystemRack

we do not assume warranty and excludes liability for possible consequential damage.

The following signals may damage the speakers:

- permanent high-level signals with high frequency and continuous noise from feedback,
- permanently distorted high-level signals,

- noises, which occur when the amplifier is on while equipment is being connected, disconnected or switched on.

Do not install devices in any of the following places:

- where the devices are permanently exposed to direct sunlight.
- where the devices are exposed to high moisture or rain.
- where the devices are exposed to strong vibrations and dust.

Damage caused by the speakers' magnetic fields

Speakers are permanently surrounded by a magnetic field, even when they are not connected. Therefore, during transport and placement of the speakers, it is important to ensure that there is always approx. 1 m between the speakers and magnetic data media and computer/video monitors.

4. Installation

4.1 Removing the Transport Covers

To remove the transport lid, turn the appropriate catches 180° to completely release the latch.

Lift the lid from the speaker.

4.2 Stacked Setup

- 1) Securely place the bottom subwoofer onto a level surface.
- 2) Stack the subwoofers on top of one another. Make sure that the plastic glider of subwoofers stacked on top of one another are securely positioned in the grooves of the lower speaker. You can connect horizontally stacked systems with the joint plates.

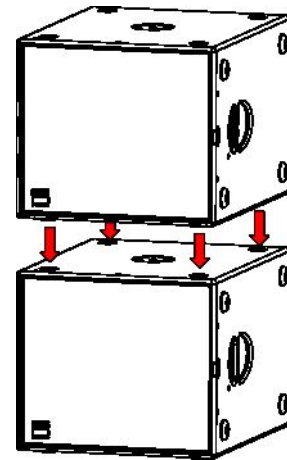

Warning

- 3) Stacked systems must be stable even if they are inclined by 15 degrees without additional additional securing. If this is not the case the systems have to be secured against falling over in order to guarantee the stability of the stack.

For example:

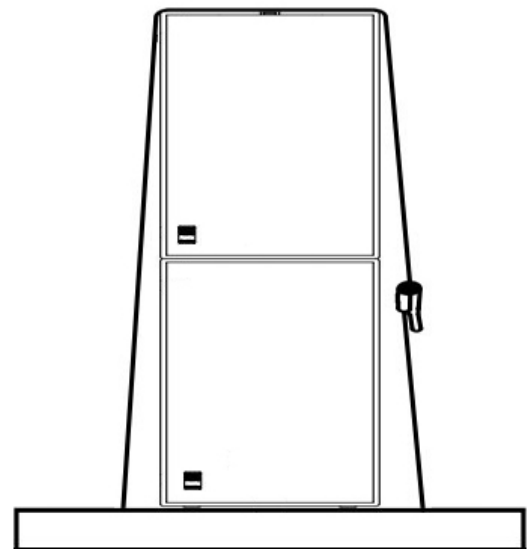

5. Suspending the Speakers

5.1 Safety instructions for flight configurations



Warning

The information described here does not relieve the user of the duty to follow the given safety requirements and legal regulations.

The technicians responsible for installing the system on site are responsible for and guarantee safe setup and use.

To prevent injury and damage, be sure to securely place or suspend the speaker as specified in the DGUV regulation 17 (BGV C1) or similar locally applicable accident-control standards.

Run the cables in a way that nobody can trip over them.

Unless otherwise stated, use only KLING & FREITAG original parts for mounting the speakers. Never use other parts (in particular, parts not made by KLING & FREITAG).

Be sure to always visually inspect all system components before use. In fixed installations, regularly check all system components for signs of wear. During the inspection, check all flying-system components carefully for deformation, cracks, bolt damage, and corrosion. Remember checking the fixing pin for proper functioning. Also check slings and lifts (e.g. shackles, chains, and steel ropes) carefully for wear and deformation. If there are signs of wear, cracks, or deformation, etc., replace the affected parts immediately. See also the "Care and Maintenance" chapter on page 26.

5.1.1 Safety Instructions for Flying Configurations

**Loudspeakers falling down impose a deadly risk for people standing near-by!
Never use the system if you have any doubt regarding its safety and reliability!**

Only qualified event technicians are permitted to suspend a NOMOS XLS system.

Maximum-load specifications refer to configurations including cabling and any fittings.

Ensure that all connections are secured against coming loose and that only authorized, statically tested and correctly sized supports, mounting equipment, wire ropes and chains are used. Follow the relevant specified safety factors. Be sure to follow the relevant national specifications, norms, and safety regulations.

Note that every suspension point as well as the supporting structure of the building (i.e. ceiling points, cross beams and stage or PA tower, etc.) must be capable of carrying the total load of the system (including cabling and additional fittings).

Note that the suspension points on the hall ceiling (i.e. shackles, attachment points, or chain hoists) must comply with the DGUV regulations 17 or similar locally applicable accident-control standards. The maximum load must have been certified by an authorized expert. When in doubt, request a confirmation by local authorities.

Even with two-fall suspension, each chain and motor must be capable of carrying the entire loudspeaker mass! Make sure that the motor chains hang down vertically and are not twisted, and that the motors are located at the required positions.

When operating with chain hoists that do not comply with the BGV C1 or the D8+, no one may be present in the danger zone underneath or near the loudspeakers.

Never use signal cables or power cords for suspending, aligning, or securing the systems. Run the cables in a way that nobody can trip over them.

Permit only personnel directly involved with assembly or disassembly to access the working area. In this case, all persons present must leave the swing and lifting range immediately.



Warning

5.1.2 Wind Loading

For open air events, obtain current local wind and weather data. The following chart provides a preliminary indication

Bft	m/s	Windspeed	Description
0	0 – 0.2	Calm	Smoke rises vertically
1	0.3 – 1.5	Light air	Smoke drift indicates wind direction, vanes do not move
2	1.6 – 3.3	Light	Wind felt on face, vanes begin to move
3	3.4 – 5.4	Gentle	Leaves, small twigs in constant motion, light flags extended
4	5.5 – 7.9	Moderate	Dust, leaves, and loose paper raised up, small branches move
5	8.0 – 10.7	Fresh	Small trees in leaf begin to sway, whitecaps on lakes visible
6	10.8 – 13.8	Strong	Larger branches of trees in motion; whistling heard in wires
7	13.9 – 17.1	Near gale	Whole trees in motion; resistance felt in walking against wind
8	17.2 – 20.7	Gale	Twigs and small branches broken off trees



Warning

For outdoor uses, we recommend using at least a BGV D8+ hoisting device to avoid wind causing the release of the secondary safety device.

If wind speeds higher than Beaufort 5 are expected, you must constantly consider the wind speed and its possible influence on the flying loudspeakers. Note that the wind speed increases with height.

With expected wind speeds exceeding Beaufort 5, construct the rigging and safety points so that they can carry at least twice the static load.

As of a wind speed of Beaufort 6, you must clear the area under the speakers. Effectively prevent the flying loudspeakers from swaying in the wind by tying them off or using a lateral fixation. If the suspended load sways, it can create significant inertial force that can result in the PA tower structurally collapsing or tipping.

With wind speeds of Beaufort 8 or more, you must lower and disassemble the flying loudspeaker.

5.2 NOMOS XLS Option 'Flight'

NOMOS loudspeakers with flying points are special models and must be ordered with the option 'Flight'.



Warning

Only NOMOS XLS speakers with flying points may be suspended. No other systems may be hung underneath, because the flying points of the loudspeakers are dimensioned only for the tare weight.

Each flying point can be loaded with 50 kg in any direction. They are suitable for K&F ball lock pins 'Lifting Pin' and screw inserts with M10 x 17 thread, e. g. a permissible ring bolt (DIN 580).

NOMOS XLS speakers must be suspended from at least two flying points. If you want to install a safety at the third flying point, the safety must be installed with zero drop height.

The NOMOS XLS subwoofer can be ordered in four different flight versions:

5.3 Possible options for flying point positions

When placing an order, you must choose an option.

Option 1:

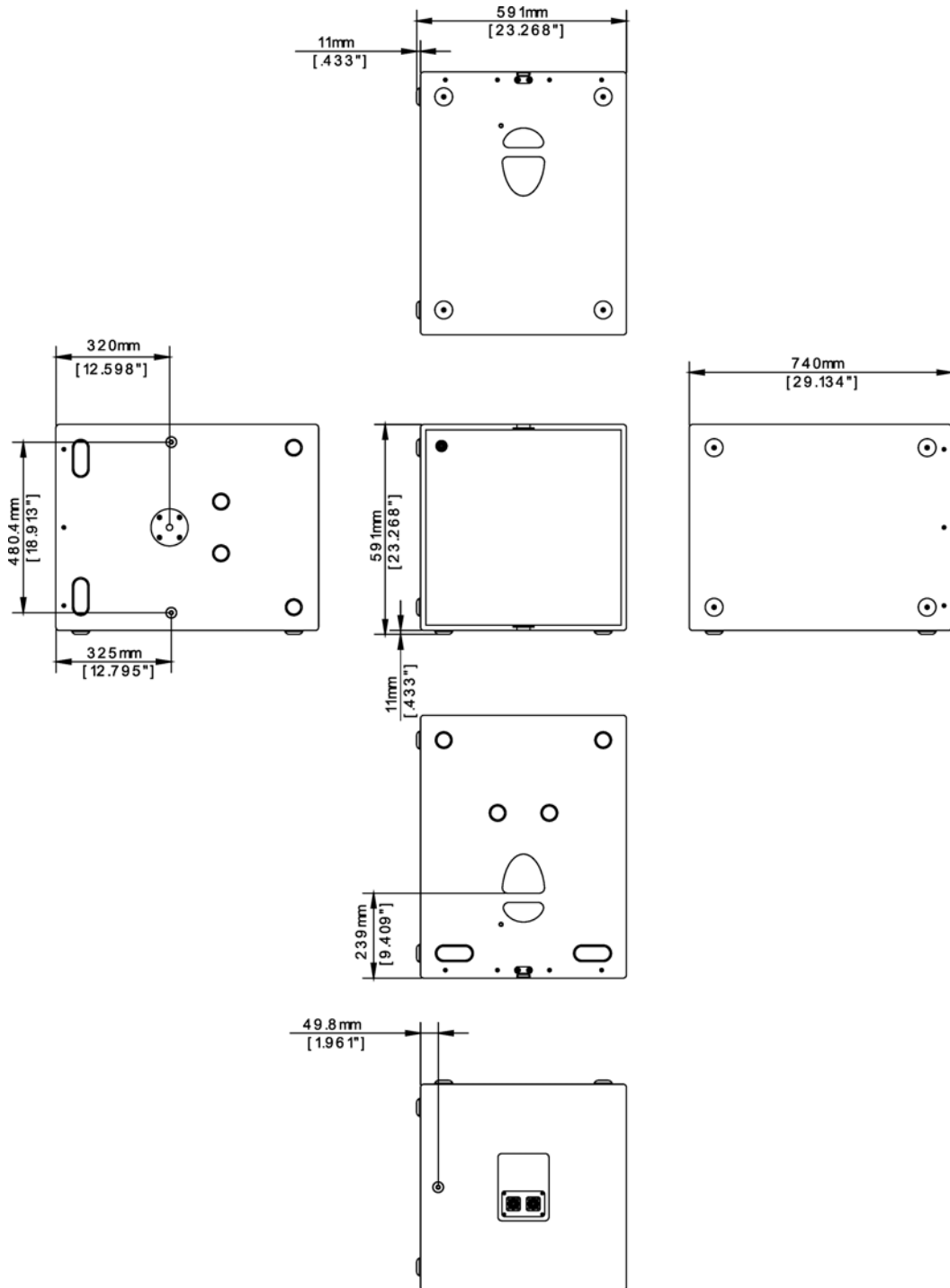

Option 2:

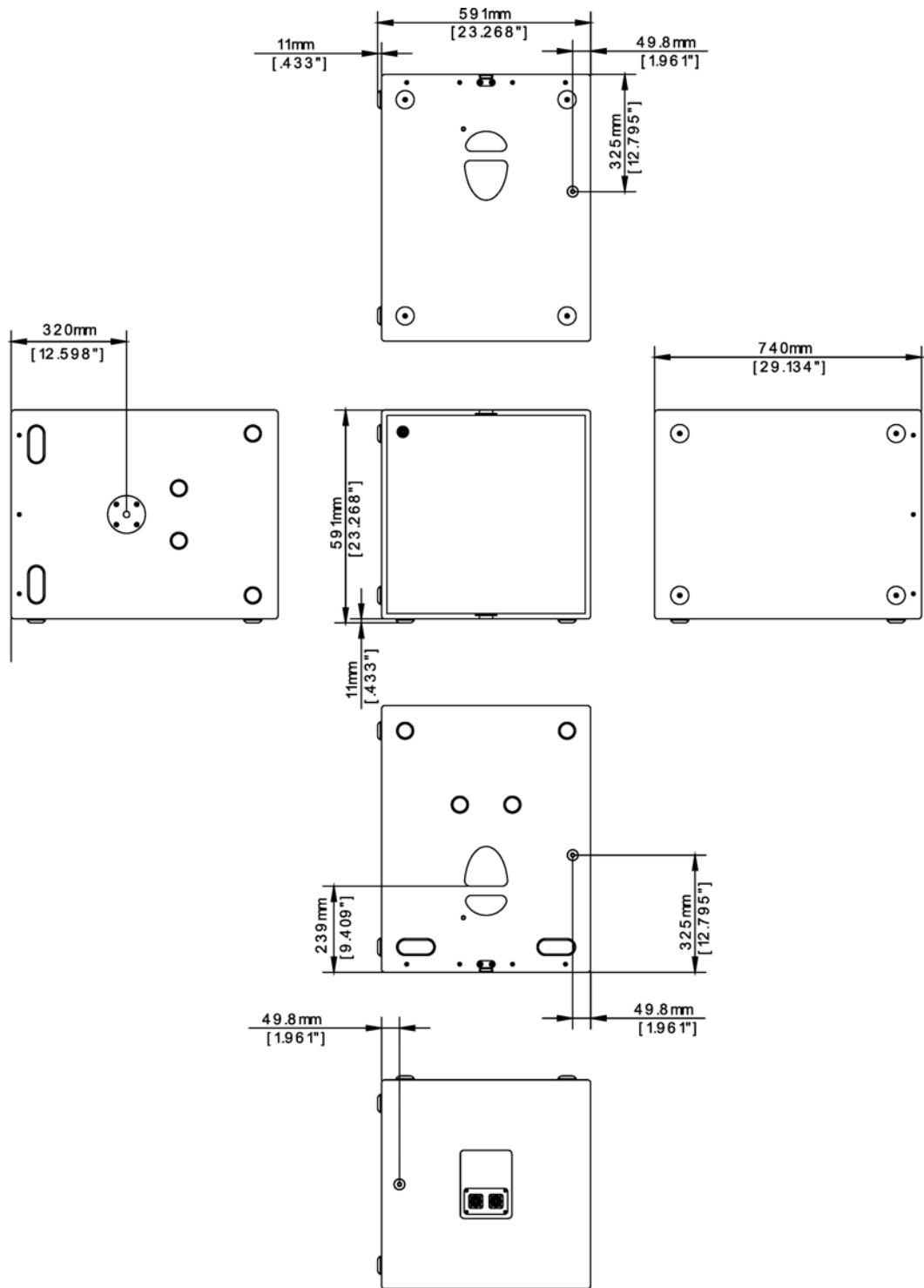

6. Configuration and Connecting Diagram

Notice

Make sure to update your K&F systemamp or systemrack with the required LS Blocks, starting with "NOMXLS".

6.1 Terminal assignment

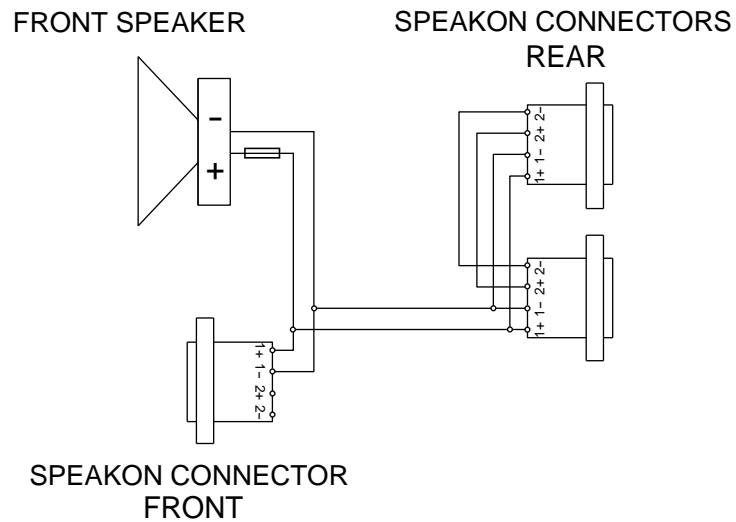

6.2 NOMOS XLS combined with other K&F tops.

The NOMOS XLS can only be combined in 2 channel mode with all K&F top speakers when using a K&F systemamp or systemrack.

To do so, select the desired LS blocks for the top speaker in the K&F systemamp or systemrack, and combine these with the LS block for the NOMOS XLS subwoofer.

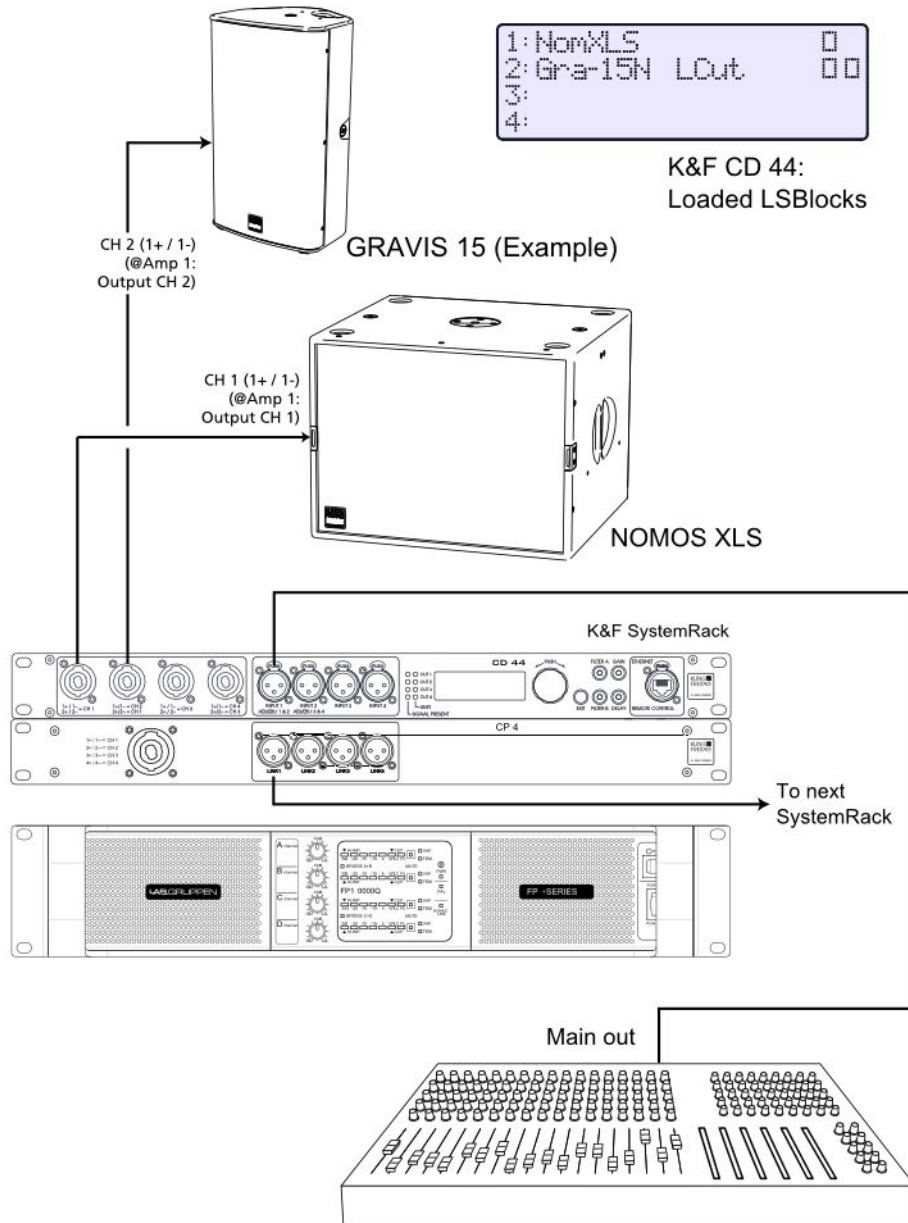

If you need a higher bass level, activate the filter 'BassBoost' via Filter B for the subwoofers.

If you need an higher level at the overlap range between subwoofer and top activate the filter 'LoMidBoost' via Filter B.

6.3 Cardioid Arrays with NOMOS XLS

The subwoofer NOMOS XLS is designed so that it can be used as a cardioid system in an array of three subwoofers, or in multiples of three.

A cardioid array results in an increase of sound pressure towards the front because of the rear-facing subwoofer. In the rear area, on the other hand, the sound pressure is clearly reduced.

With this, you achieve

- less unwanted sound on the stage
- low feedback
- simplified miking
- improved room acoustics with fewer reflections from the rear and side walls, or – when flown – from the ceiling
- simplified adherence of sound emission limits and therefore less noise disturbance for nearby residential areas during open air events.

6.3.1 Setup instructions for a cardioid array

To achieve a cardioid pattern, you must always have an array with 3 subwoofers - or a multiple of 3 subwoofers - setup next to one another (3, 6, 9, etc.). In this set of three, the middle one must be rear-facing while both other subwoofers are front-facing.

You can choose from the following options for cardioid and hypercardioid setups:

Principle drawing:

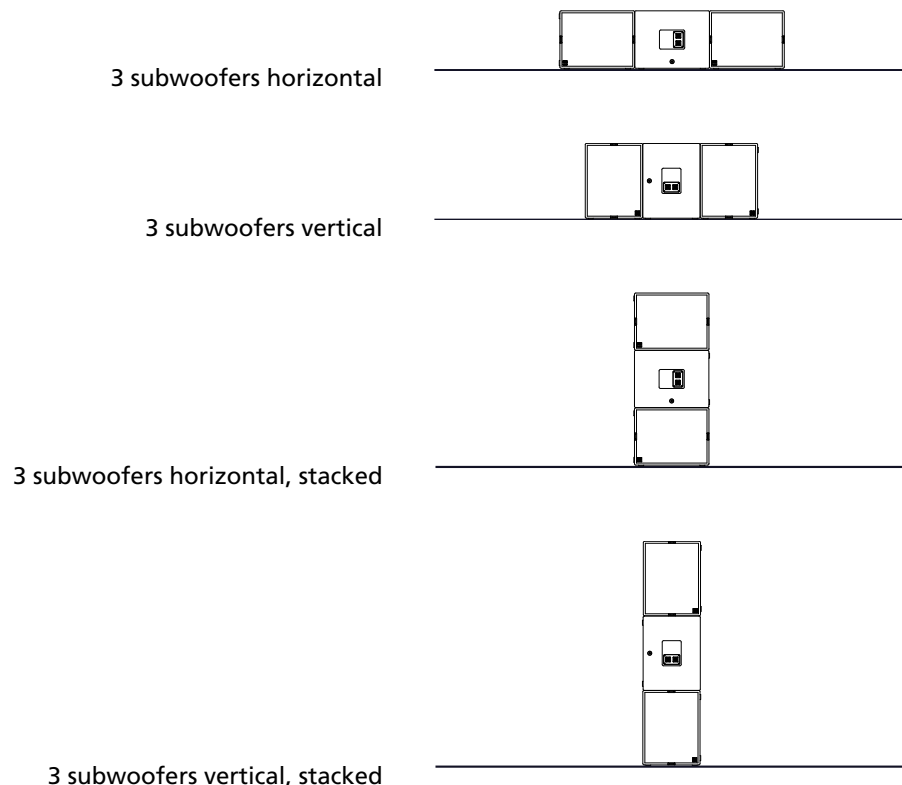

When cardioid arrays are stacked on the floor, ensure that there is always a distance of at least 40 cm between each unit of 3.

Principle drawing:

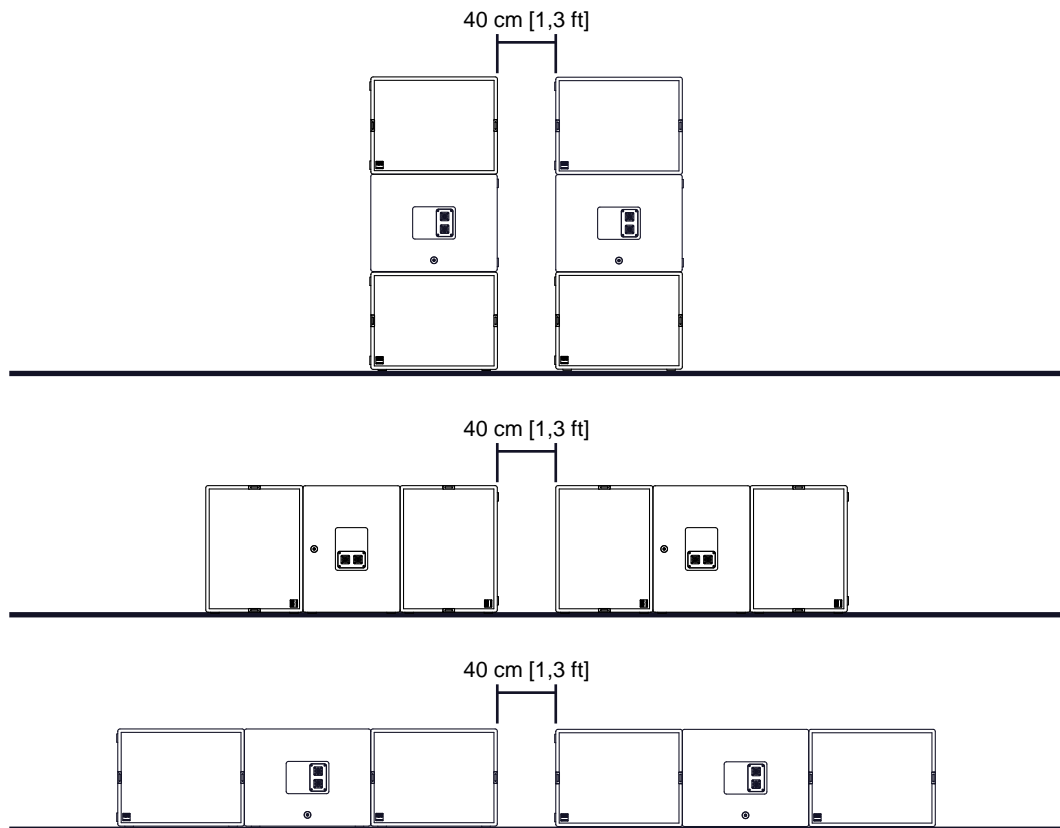

6.3.2 LSBlocks for cardioid use

The rear-facing subwoofer is controlled using the systemrack or systemamp via LSBlock for cardioid arrays for rear-emitting subwoofers. The front-facing subwoofers are controlled via LSBlock for cardioid arrays for front-emitting subwoofers. The following cardioid LSBlocks are available:

Operating mode	Chassis	LSblocks*
'Cardioid'	front	NOMXLS C-F
	rear	NOMXLS C-R
'Hypercardioid'	front	NOMXLS H-F
	rear	NOMXLS H-R
'Infrabass Cardioid'	front	NOMXLS C-F60Hz
	rear	NOMXLS C-R60Hz
'Infrabass Hypercardioid'	Front	NOMXLS H-F60Hz
	Rear	NOMXLS H-R60Hz

6.4 Cardioid Configurations with different Speakers

NOMOS XLS are suitable for cardioid configurations with certain K&F speakers. A chassis ratio of 1 to 2 should be maintained within these configurations.

Notice

The speaker with one chassis should be standing on the floor and directed to the rear while the speaker with two chassis directs to the front.

1 x NOMOS XLS under NOMOS XLT standing

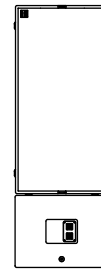

7. Fuse in the NOMOS XLS

To increase the operating safety of the NOMOS XLS, the subwoofers are equipped with fuses at the signal input. These fuses reduce the risk of consequential damage resulting from a short circuit (i.e. charred cables / connectors / fire damage).

Notice

When the fuse is burned out, then the chassis is most likely already ruined, as the fuse just prevents consequential damage resulting from a short circuit of the chassis. A replacement of the chassis is, therefore, unavoidable.

7.1 Replacing the Fuses

The fuse holder is behind the terminal.

Replace the fuse with the following original fuse only:
Bussmann S 506-8A, T 250 V



Warning

Required tools:

- 2.5 mm Allen key for loosening the terminals

Instructions:

1. Loosen the four screws on the terminal.
2. Carefully pull the cables out of the speaker enclosure.
3. Open the fuse holder.
4. Replace the blown fuse.
5. Push the cables carefully back into the enclosure.
6. Pay attention to the correct alignment of the terminal.
Screw the terminal back on.

7.2 Replacing the Chassis

Required tools:

- 3 mm Allen key for loosening the front grille
- 4 mm Allen key for loosening the chassis

Instructions:

1. Remove the front grille.
2. Remove the speaker chassis.
3. Pay attention to the correct polarity of the chassis.
Connect the new chassis.
4. Check the polarity of all mounted chassis.
5. By tightening the screws diagonally in two steps, a deformation of the chassis and thus a possible decentering of the voice coil can be avoided. First loosely fasten the screws for the chassis diagonal from one another, then tighten them.
6. Mount the front grille.

8. Dimensions NOMOS XLS

Weight: 41.3 kg

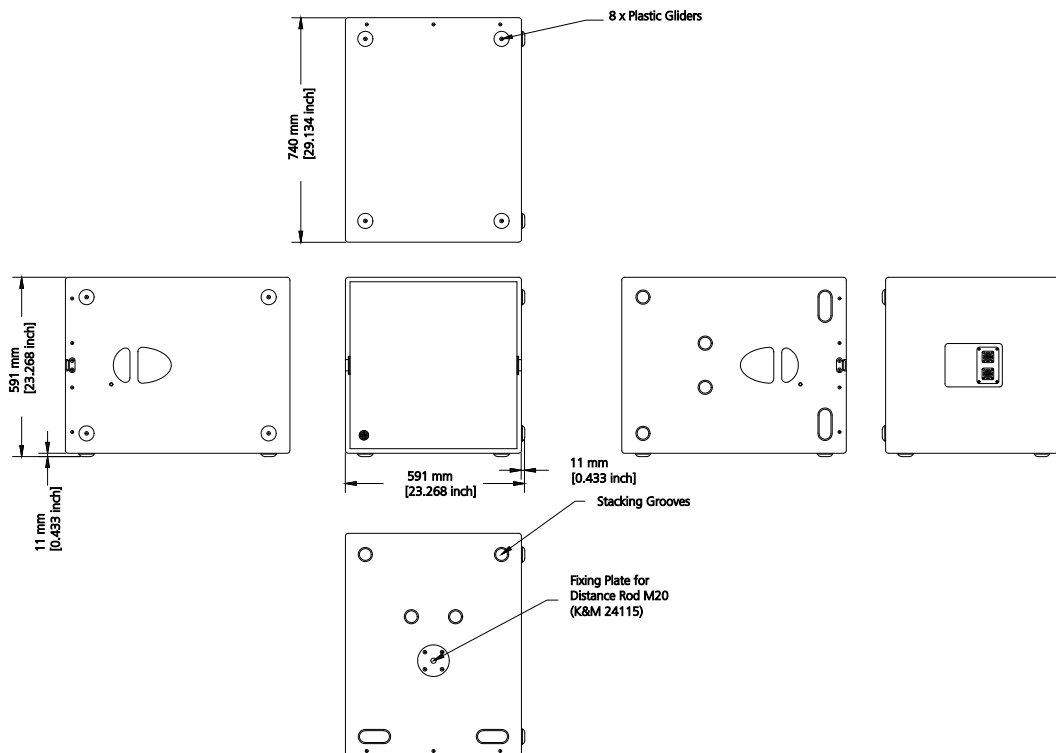

9. Measuring Diagrams

Polar Patterns

Cardioid

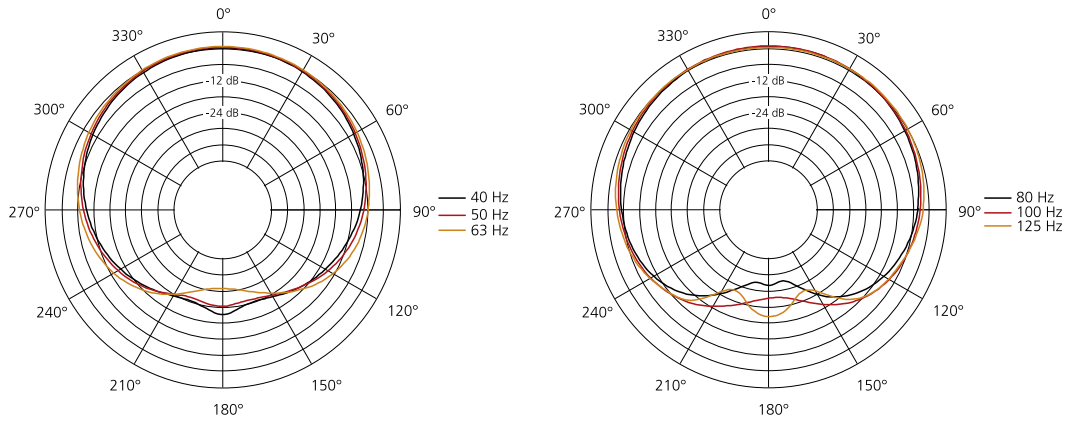

Hypercardioid

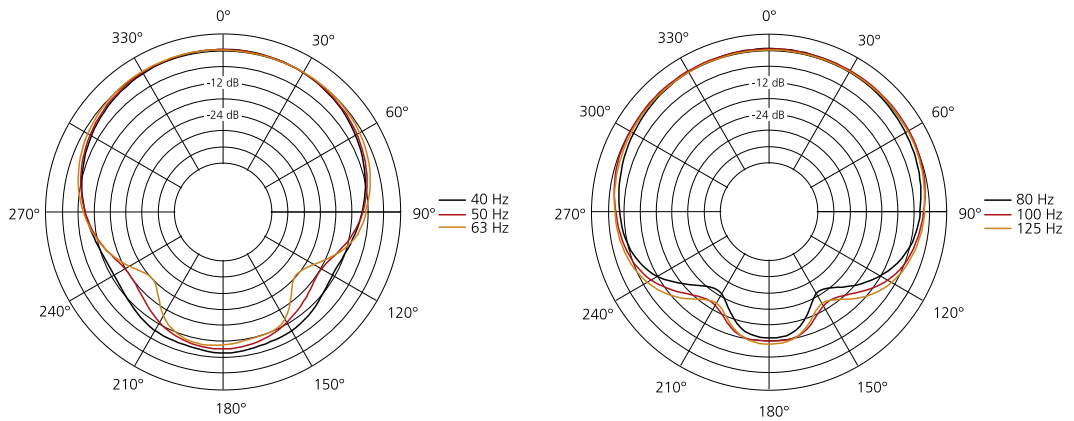

Note: Attenuation factor depends on setting and configuration (see page , "Configuration and Connecting Diagramm").

Frequency response

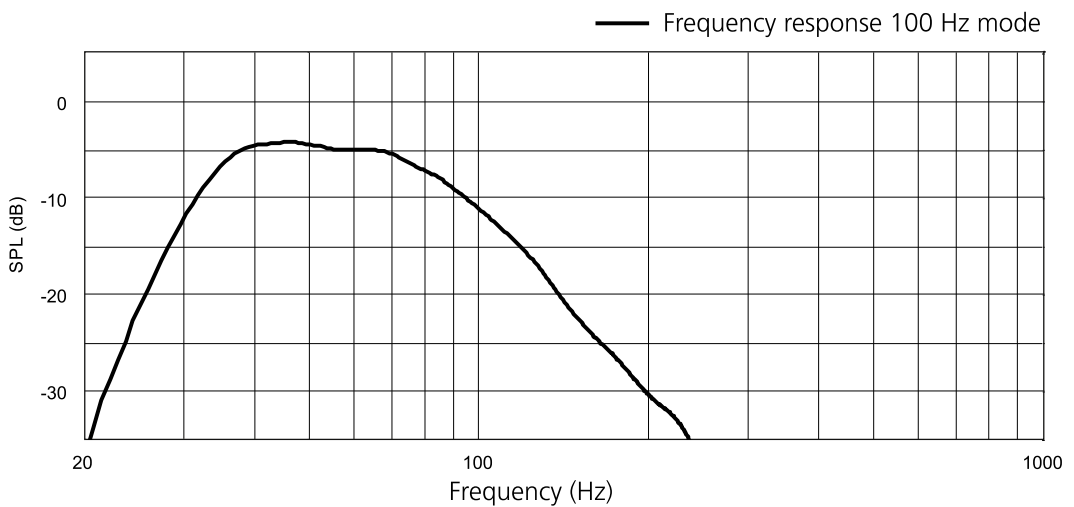

10. Technical Specifications

NOMOS XLS	
Concept	Bass reflex system
Operated with	K&F PLM+ Serie, K&F D-Serie, K&F SystemRack, K&F TOPAS
Crossover frequencies	100 Hz/60 Hz
Lower cut-off frequency	29 Hz (-10 dB)/33 Hz (-3 dB)
Coverage	Omnidirectional (a cluster of 3 or in combination with the NOMOS XLT can be driven in cardioid)
Nominal power handling	750 watts
program	1.500 watts
peak	3,000 watts
Max. SPL (1 m)	136 dB (SPL Peak/1 m/half space)
Nominal impedance	8 Ohm
loudspeaker/channel	see matrix
Components	18" subwooferchassis, 57 mm peak-to-peak excursion, inside and outside ventilated voice coil gap for reduced power compression, aluminium demodulating ring for very low distortion
Connection	2 x speakON® 4-pol NLT4MP (+1/-1) (hinten) 1 x speakON® 4-pol NLT4MP (+1/-1) (vorne) IN parallel zu OUT
Enclosure Design	
	Frame reinforced enclosure, 15 mm multiplex with highly resilient Polyurea synthetic coating with 2 ergonomical butterfly handles 8 non-abrasive plastic sliders and stacking grooves for save stacking of NOMOS XLS and XLT and Line 212, 2 locking profiles for optional transport cover, additional Speakon®-connector hidden behind the rotatable logo on the front grille, ball-proof steel grille with black acoustic foam
Dimensions (H x W x D)	591 x 591 x 740 mm
Weight	41.3 kg
Color	RAL 9005 (black)
Options	'Suspension' with 3 K&F VariPoints®, 'RAL Special Colour'

11. EC Declaration of Conformity

EG-Konformitätserklärung NOMOS XLS
(Declaration of EG-Conformity)



Hersteller:
(Manufacturer) Kling & Freitag GmbH
Junkersstraße 15
30179 Hannover
Deutschland

*Bevollmächtigter für die
Zusammenstellung der
technischen Unterlagen:*
(Authorized representative for
the compilation of the technical
documents) Kling & Freitag GmbH
Abt. Entwicklung
049 (0)511 96997-50
Deutschland

Produkt:
(Product) **Lautsprechersystem
NOMOS XLS**

**Wir erklären, dass das genannte Produkt den aufgeführten Schutzanforderungen der
folgenden EG-Richtlinien entspricht:**
(We declare that the designated product is in conformity with the protection requirements
imposed by the following EU directives)

- 2014/35/EU, Niederspannungsrichtlinie
- VDE 0042-12:2013-02, Technische Dokumentation zur Beurteilung von Elektro- und Elektronikgeräten hinsichtlich der Beschränkung gefährlicher Stoffe

Hannover, 20. November 2017



Jürgen Freitag
(Geschäftsführer)

12. Accessories

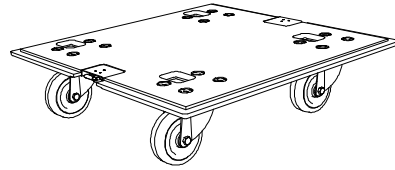
Transport Cover NOMOS XLS

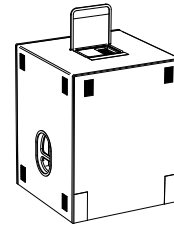

Protective Cover NOMOS XLS



Loudspeaker patch cable NLT-425, 5 m

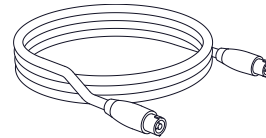

13. Care and Maintenance



Warning

For the owner and user, it is mandatory to be aware of the safety relevance of speakers that can be flown.

The NOMOS XLS system can exhibit signs of wear over the years, for example, from mechanical strain, transport damage, corrosion, or improper handling. Remember that flying speakers always impose a high safety risk.

Generally, perform a visual inspection of your speaker every time you suspend it or take it down. In fixed installations, check the speaker for signs of wear at regular intervals.

When performing those checks, particularly look for deformations, cracks, dents, damage to threads, and corrosion. Also check slings and lifts (e.g. shackles, chains, and steel ropes) carefully for wear and deformation.

If as a result of these checks any uncertainty should arise with regard to safety or defects are found, don't use the speaker any longer.

Inspection regulations may vary depending on application and country of use. Observe all applicable regulations; when in doubt, contact the local authorities.

Many countries require regular inspection of mounting components and accessories. An additional annual inspection is typically required to be performed by a technical expert. Moreover, a legally certified or official authority must perform a detailed inspection every four years.

Therefore, be sure to maintain an inspection log. Enter the values determined for each speaker and accessory during the periodic checks into this log. This way, relevant data are always at hand in case of inspection. The log should also document maintenance measures and inspection intervals and contain parts lists.

The Polyurea synthetic coating used by KLING & FREITAG is impact proof and highly resistant. We recommend using protective coverings or transport cases to help avoid damaging the paint in case of continuous mobile use, etc.

To replace the filter foam, send the front grille incl. foam to KLING & FREITAG GMBH. Upon payment for expenses, the grille with the new covering will be returned.

14. Transportation and Storage

The NOMOS XLS is protected against short-term moisture. despite, be sure to store, transport, and use the accessories in dry environments only. The NOMOS XLS System is not designed for long-term use in a corrosive environment.

Make sure that the system is adequately ventilated during longer storage periods so any residual moisture can escape from the equipment.

Furthermore, you should ensure that the NOMOS XLS System is protected from mechanical strain to prevent possible damage.

We recommend using suitable transport and storage cases and the optional soft cover that protects from the above-mentioned influences.

15. Disposal

Recycle the packaging material of the device.

15.1 Germany

Don't dispose of waste electrical equipment through household waste.

Don't deliver it to official recycling points either.

All KLING & FREITAG products are plain business-to-business (B2B) products. Therefore, KLING & FREITAG GmbH is exclusively responsible for disposing of all KLING & FREITAG waste equipment marked with a garbage-can icon. Call the below phone number when you have a KLING & FREITAG product (marked with the garbage-can icon) for disposal. We will offer you a straightforward and professional disposal at no cost.



KLING & FREITAG equipment with no such icon was sold before 24 March 2006; in that case, the owner is legally responsible for disposal. We will, however, gladly assist you by naming appropriate ways of disposal.

For further disposal information of KLING & FREITAG waste products, call +49 (0)511-96 99 7-0

Background information: The Electrical and Electronic Equipment and Appliances Act (ElektroG) is the German implementation of the European (EU) Waste Electrical and Electronic Equipment Directive (WEEE, 2002/96/EC).

Therefore, starting on 24 March 2006, KLING & FREITAG GmbH has marked all products subject to the WEEE that are distributed in Germany with an icon showing a crossed-out garbage can with a white bar below it. The icon indicates that the equipment was distributed on or after 24 March 2006 and must not be disposed of through household waste.

KLING & FREITAG GmbH is legally registered as a manufacturer with the German waste-equipment registration authority (EAR). The WEEE registration number is: DE64110372.

We substantiated towards the EAR that our products are for B2B trade only.

15.2 EU, Norway, Iceland, and Liechtenstein

Don't dispose of waste electrical equipment through household waste.

Starting on 13 August 2005, KLING & FREITAG GMBH has marked all products subject to the WEEE directive that are distributed in any member state of the European Union (except Germany), Norway, Iceland, or Liechtenstein with an icon showing a crossed-out garbage can with a white bar below it.



The icon indicates that the equipment was distributed on or after 13 August 2005 and must not be disposed of through household waste.

Unfortunately, the European WEEE directive was implemented in different national legislation in the EU member states, making it impossible to offer a consistent disposal solution throughout Europe.

The local distributor (sales partner) in the respective country is responsible for complying with the applicable legislation.

Contact your retailer or the local authorities for information on the regulations applicable in any EU member state (except Germany).

15.3 All Other Countries

Contact your retailer or the local authorities for information on the regulations applicable in any country not listed above.

INDEX

• Accessories.....	25
• Cardioid.....	20
• Care.....	26
• Components.....	6
• Connection.....	16
• Dimensions.....	21
• Disposal.....	27
• EC Declaration of Conformity.....	24
• Flying points.....	11
• Fuse.....	20
• Installation.....	10
• Items Included.....	6
• Maintenance.....	26
• Measuring Diagrams.....	22
• Operating Safety.....	8
• Product Description.....	6
• Protecting the Speakers.....	8
• Safety Instructions.....	7
• Storage.....	26
• System Requirements.....	7
• Technical Specifications.....	23
• Transportation.....	26
• Transport cover.....	10
• Wiring Diagrams.....	16